

ZW8-12 series vacuum circuit breaker, rated voltage of 12KV, the three-phase AC 50 HZ high voltage outdoor switchgear equipment, mainly used for breaking off site, city network and small power system load current, overload current, short circuit current.

The product overall structure for the three-phase together box type, three-phase vacuum arcing chamber placed in a metal cabinet, using SMC insulating materials and insulation and insulation to ground, reliable performance, high dielectric strength.

ZW8 – 12G is composed of ZW8-12 circuit breaker with a assembly of the isolation knife, called a combination circuit breaker, can be used as the section switch, also self-contained power supply, have internal PT & external PT. The series of products of operating mechanism for CT23 spring energy storage type operating mechanism, divided into electric and manual.

Technical Data

1	Rated voltage			12	
2	Rated insulation level	1 min power frequency withstand voltage (electrode, ground/fracture)	KV	Dry	42/49
		Lightning shock compression (electrode, on the ground)		Wet	34
		Lightning shock compression(fracture)			75
					85
3	Rated frequency		HZ	50	
4	Rated current		A	630	
5	Rated short circuit breaking current		KA	20	
6	Rated short circuit making current (peak)		KA	50	
7	Rated short time withstand current		KA	20	
8	Rated short circuit closing current peak		KA	50	
9	Mechanical life		Times	30000	
10	Rated operating sequence			off-0.3S-on off-180S -on/off	
11	Rated closing voltage of operation mechanism		V	110,220	
12	Rated closing voltage of operation mechanism		V	110,220	
13	Rated short circuit breaking current breaking times		Times	30	

Outline Dimension

ZW8-12

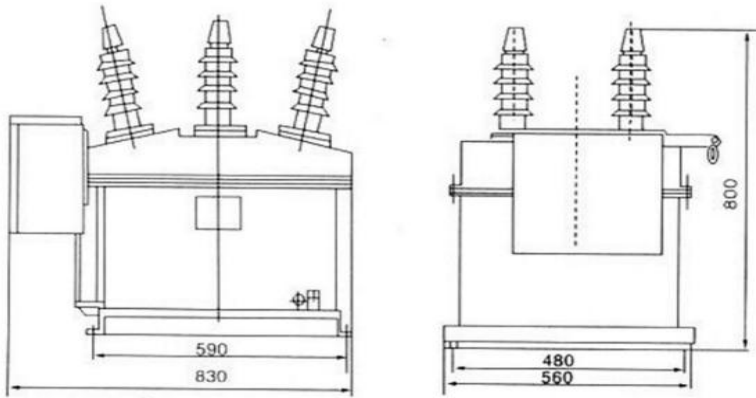

ZW8-12G

